



# Bath Christmas Market

## Catering Information 2025





# About Bath Christmas Market

Bath Christmas Market is the biggest annual event in Bath, attracting over 450,000 people to the city each year. Founded in 2001, Bath Christmas Market has evolved to become one of the most recognized Christmas Markets in the UK.

Our vision for the event is to:

- Provide a platform for some of the best makers from the South West and beyond
- Become a launchpad for micro-businesses to test products
- Positively impact the lives of visitors, residents, and traders
- Become the best Christmas Market in the UK!

# Why Bath Christmas Market?



Ranked the Best Christmas Market in the UK



Estimated footfall of 444,000 people



Average Visitor spend of £31 per person per day



Marketing and PR reach of over 100 million people



98% of stallholders regard Bath Christmas Market as a success for their business

## Important Dates and Opening Hours

Bath Christmas Market 2025 will run for 18 days from Thursday 27th November until Sunday 14th December (inclusive), with our residents' preview evening taking place on Wednesday 26th November from 5pm to 7pm.

The trading times are:

Monday - Wednesday: 10am - 7pm

Thursday - Saturday: 10am - 8pm

Sunday: 10am - 6pm

In addition to this, the load-in period for BCM will occur from Friday 21st November to Wednesday 26th November.

All catering units are 18-day lets and you **must** remain open for the full opening hours of the market.

# Your pitch hire includes...

01

## Your Pitch

Catering chalets are built for you and ready to be decorated once you arrive. Pitch-only rentals and mobile pitches do not come with a permanent structure and you must provide your own

02

## Dedicated Event Management

Our experienced event team are available for any questions you have in the run-up and during the event. During the event, you will have a dedicated zone managers to help with queries

03

## Community Membership

We have dedicated stallholder newsletters and a Facebook group so that you can receive all the relevant information, offers and gain advice from other stallholders

04

## Electricity

As standard each catering unit has access to either a 16amp or 32amp supply, you will be told what your allocated usage is if successful.

05

## Security

During the event, Bath Christmas Market has 24-hour security patrolling the site. Please note: you must supply your own padlocks.

06

## Marketing

Dedicated web page on our website with links to your own website, and ongoing marketing and PR support.

# ...and more!

# Pitch Options

Particularly on the weekends, Bath Christmas Market can get busy. You must ensure that you can meet the food demands of our visitors quickly and effectively. You should also consider your queuing system when choosing your pitch.

## Pitch-only Rentals

We have a range of pitch-only catering options available. We invite anyone with an interesting and unique catering offer that fits the market aesthetic to apply. For our pitch-only rentals, you **MUST** provide a clean, well-dressed gazebo or structure (max 3m x 3m) that is in keeping with the market aesthetic, and you must ensure your pitch is well lit.

We want to see applications from a range of providers including food and beverage caterers that can offer something our visitors won't find anywhere else.

## Mobile Catering Units

These are smaller pitches designed for transportable units that can be moved on and off-site if required. These can be anything from a quirky bike serving delicious goodies, to a airstream bar ready to quench our visitor's thirsts.

Previous mobile catering units include horseboxes, vintage cars, catering bikes, and carts.

## Catering Chalets

Catering Chalet are purpose-built structures ready for you to move straight into. You can choose your own decoration in keeping with the Christmas Market guidelines. Due to the nature of the construction of the chalets, all dimensions are approximate

Our catering chalets are situated in key locations across the market and are available in a variety of sizes to suit your set up. We are looking for a range of hot food providers that cater to a range of dietary preferences. Please note: all catering chalets **MUST** have vegetarian options.



# Catering Chalets

These structures are built by our team and ready for you to decorate. There are three size options for these outlined below:

Small: 2000cm depth x 2100 height x 2500 width

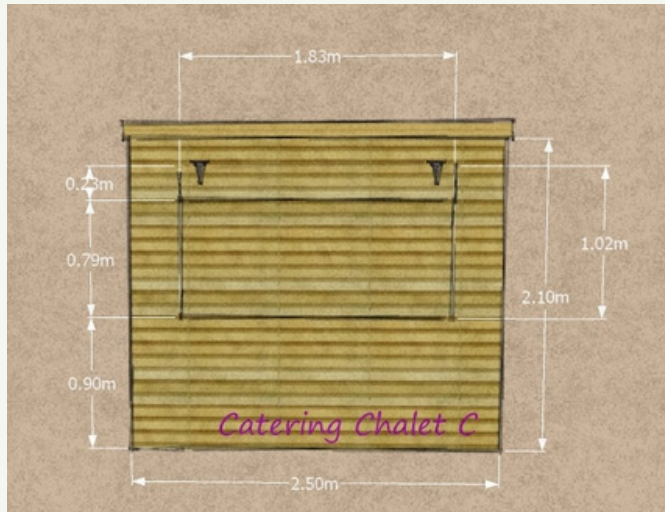

Medium: 2000cm depth x 2150cm height x 3500 width

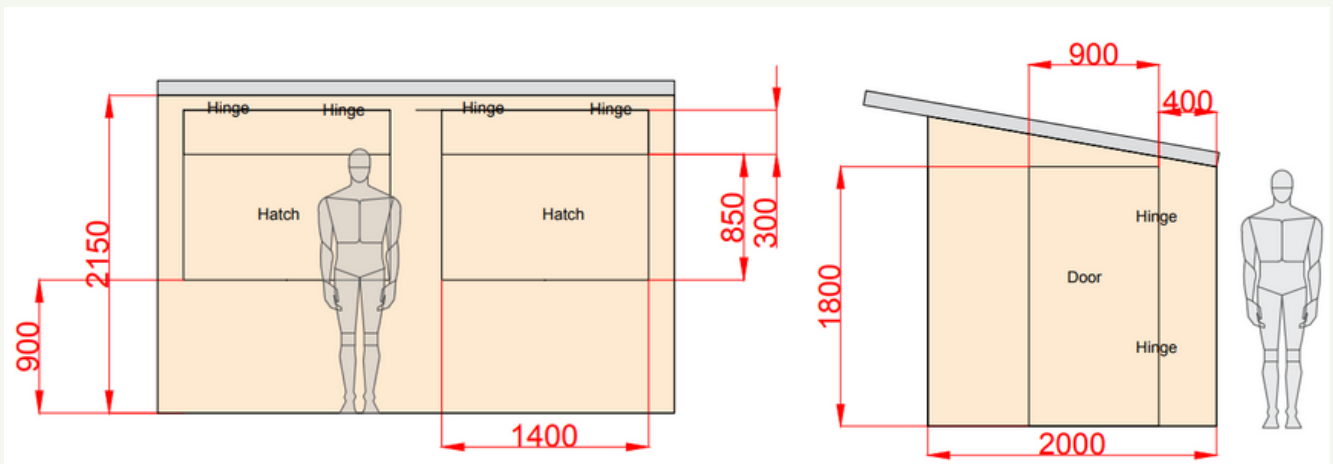

Large: 3000cm depth x 2150cm height x 4000cm width

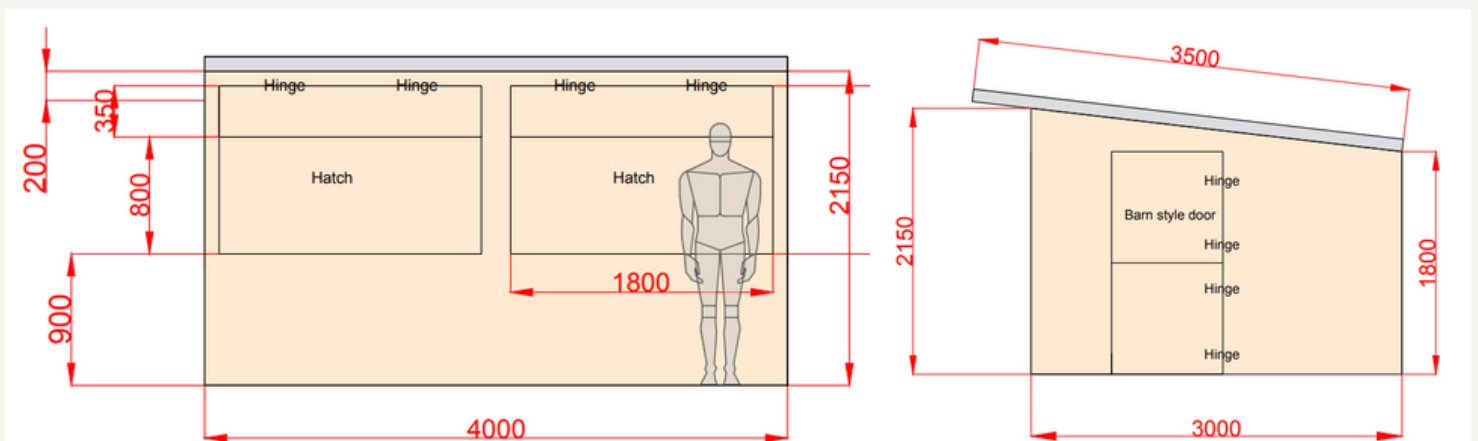

# The Application Process

Applicants must complete an online application via our website before Wednesday 30th April. These are not on a first-come, first-served basis so please take the time to include as much information as possible. Please be aware that catering proposals will only be considered if they are accompanied by a detailed description of your products and any dietary preferences you cater for. This is the case for both new and repeat proposals. **If you have attended the market before, this does not automatically grant you a place in the 2025 market.**

We recommend that you demonstrate the quality of your food and how it is served by providing high-quality photographs of the products you intend to sell.

When completing your application, please refer to the event site plan. This is important, as site plans and pitches can change each year.

The event organisers consider all applications equally and do not take into consideration previous attendance at the market when choosing the final shortlist. They also curate the event to include a range of food and beverage options and take into consideration what is already available in the city so as not to compete with the current retail offering.

When applying, you will be asked to provide a series of descriptions and photographs of all items that you intend to sell.

## Sustainability

We want Bath Christmas Market to have a minimal impact on the environment and we have pledged to be as sustainable as we possibly can. For this reason, all caterers **must** refrain from using single-use plastic and should use environmentally-friendly alternatives. If you have a particularly unique approach to sustainability, let us know!



**I.**

Read all of the information on the Bath Christmas Market website

**2.**

Choose your preferred pitch

**3.**

Gather all of the relevant information outlined in the application

**4.**

Submit your application for Bath Christmas Market 2025!

**5.**

Once applications close, the panel go through the applications. We hope to get back to you by July.



# Our Selection Criteria

Bath Christmas Market is a popular event, receiving many high-quality applications from a wide range of exceptional caterers. We take into consideration many different elements when deciding on our final shortlist including the following points:

<b>Locality</b>	We are interested in knowing not-only where your business is based, but also where your produce is from.
<b>Quality of produce</b>	We want to ensure that the food on offer at Bath Christmas Market is using some of the best produce. Please outline this in your application.
<b>Ethics of the business</b>	All produce must be ethically sourced, sustainable, and fair trade. Your business should also take a sustainable approach to the way you transport and supply food.
<b>Product Range</b>	We take into consideration the product range you wish to sell and how they feed in to the wider market. Please outline all products you wish to sell alongside any dietary preferences you cater for.
<b>Retail Mix</b>	Bath has a huge variety of top quality food and beverage retailers located within the city centre. Our caterers should be able to offer something 'different and unique' to is already on offer on the high street. There are also certain types of product that would not be deemed acceptable for trade at this market.
<b>Customer Profile</b>	We want to ensure that we have variety in our products that suit a wide range of our visitor profiles and dietary preferences.
<b>Price Range</b>	We are looking for a range of variously priced products so that customers with all budgets can enjoy a bite to eat. (The application form asks to state minimum and maximum prices of your products).

# Additional Information

## Our expectation of caterers

Those joining us at Bath Christmas Market are expected to represent the Bath Christmas Market brand from the moment they reserve their pitch. During your time at the market, you must follow the Terms and Conditions, along with any instructions from event staff on the ground. Failure to do so could compromise your attendance at the event. The event organisers reserve the right to terminate your attendance should they find you in breach of the terms of attendance.

You are expected to be ready and trading throughout the duration of the market and should ensure you have adequate staff to cover breaks etc on our busy days. Event control do facilitate this where possible however this is not guaranteed.

## Event Management Support

Bath Christmas Market has a dedicated and experienced event management team that is on hand in the run-up and duration of the event to help with any queries you have and to ensure the safe running of the event. The site is also monitored 24/7 by security staff, including overnight.,

We have a dedicated event control number which will be on display in your chalet at all times. This number is monitored 24/7 and should be used for any emergencies or maintenance issues during the event itself.

## Decorating your pitch

Every year, we love seeing the creativity that our stallholders and caterers have. However, we do have some house rules when it comes to decorating your chalet. Whilst you are responsible for the decoration of their chalets, Bath Christmas Market reserve the right to request any changes to the decorations. All lights must be warm white, LED lights, including any decorative fairy lights. No coloured lights are permitted without prior approval from the Events team. You must also ensure your pitch is kept tidy and complies with health and safety regulations. If you are asked to make changes to this, you must do so in a timely fashion.

## Marketing and Publicity

Bath Christmas Market has dedicated Marketing and Publicity staff that are working to promote the event throughout the year. We are currently in the process of planning our stallholder marketing campaign and all successful stallholders will be contacted about ways they can get involved.

## Electricity and PAT testing

As standard each catering unit has access to either a 16amp or 32amp supply, you will be told what your allocated usage is if successful. For an additional 16amp or 32amp supply you would need to make this request once successful and for an additional charge. Please see the catering price list for details. Electricity usage will be monitored by our electricians, so everyone must stay within this consumption limit. Failure to do so may result in a power failure. Power to catering units is included in the rent.

All electrical equipment must have a PAT (Portable Appliance Test) certificate unless you can demonstrate that it is brand new with receipts of purchase. You will not be permitted to use any untested equipment within your chalet/on-site. We will have qualified electricians on-site during the build of the event who can carry out PAT testing of your appliances for a charge of £7+VAT per item. If the event electricians deem any electrical items to be unsafe or not fit for purpose, we will be unable to let you continue using them. Naked flames, candles, etc are not permitted as part of your display or anywhere in your chalet without the permission of the event organisers, and are subject to an on site risk assessment.

## Public Liability Insurance

All stallholders trading at Bath Christmas Market must hold Public Liability Insurance for no less than £5million. If you are a member of the National Market Stallholder's Federation, you are automatically covered for the necessary Public Liability cover. Evidence of this should be provided in advance of the event. Any stallholder that doesn't provide this information will not be permitted to enter the Market site and may forfeit their place.

## Waste Water Management

We do not provide any large scale waste water facilities, grey waste liquid must be removed by yourselves. In some circumstances, individual arrangements may be considered at the discretion of the organiser. Please provide details of your water and waste water requirements.

## Residents' Discount

Bath Christmas Market is an event that aims to bring communities together and we want to encourage people within our community to enjoy the city at Christmas time. For this reason, we ask all caterers to provide a discount or offer that they can use with proof of address. Some examples of this could be 20% off or 2-4-1. These should be valid from Monday - Friday.

In addition to this, on Wednesday 26th November at 5pm, all residents will have the opportunity to preview the market before we open to the general public. All caterers will also need to be present and able to trade during this time.



Thank you for your interest in applying for a catering pitch at Bath Christmas Market 2025.

Due to the high volume of applications we receive, we are unable to offer individual feedback so please accept that the decision of the selection panel is final. We cannot arrange individual meetings to discuss applications or view product samples.

Good luck!

Tilley and Hannah.



[christmas\\_market@bathnes.gov.uk](mailto:christmas_market@bathnes.gov.uk)



[www.bathchristmasmarket.co.uk](http://www.bathchristmasmarket.co.uk)